

# Charlie® STRONG-ARM



**FLOOR SAFE**  
MODEL NO: CS150F  
PART NO: 7710175

**OPERATION & MAINTENANCE  
INSTRUCTIONS**

---

## INTRODUCTION

---

Thank you for purchasing this CLARKE Floor Safe, designed for discrete fitting beneath floorboards.

It is strongly recommended that installation is carried out by a qualified tradesman to avoid the possibility of structural damage - to pipes, cables, joists etc., which may be in the vicinity. It is also possible to wall mount the safe if desired.

---

## GUARANTEE

---

This CLARKE product is guaranteed against faulty manufacture for a period of 12 months from the date of purchase. Please keep your receipt as proof of purchase.

This guarantee is invalid if the product is found to have been abused or tampered with in any way, or not used for the purpose for which it was intended.

Faulty goods should be returned to their place of purchase, no product can be returned to us without prior permission.

This guarantee does not effect your statutory rights.

---

## REPLACEMENT KEY

---

A key number has been carved into the face of the keys. This number must be registered with us in the event you require a replacement key.

Please complete the registration form at the website on page 4. If you fail to register the safe we will not be able to provide you with a replacement key.

We recommend that in addition to registering the safe, you record the number in the space provided. Please retain this document for future reference.

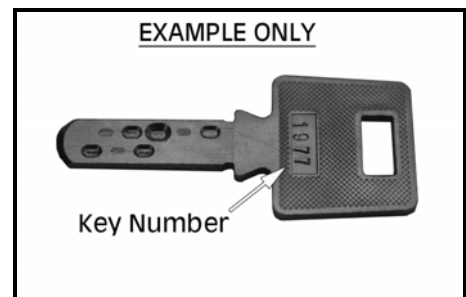

# INSTALLING YOUR SAFE

**NOTE:** To install the safe, it will be necessary to cut a hole into the floorboards, which must be located between two joists. Great care must be exercised to ensure there are no cables or pipes at the installation point, which could be damaged when drilling or sawing through the floorboards.

When locating the safe, and BEFORE cutting floorboards, ensure the measurement from the top surface of the floorboard to the floor below is at least 135mm, see Fig.1. This is to ensure the safe does not bottom out when fitted.

Once the location has been determined proceed as follows.

1. Mark the hole position, the dimensions being **390mm x 210mm** (see Fig.2).
2. Using a suitably sized drill bit, drill a hole in each corner of the marked hole to enable a jig saw blade to pass through.
3. Using the jigsaw, carefully cut out the hole, finishing off by sandpapering all rough edges.

**NOTE:** Generally, floor joists are 16" (405mm) apart. The safe box is 336mm in length (see Fig.1). It is necessary therefore, to attach battens to the joists as shown in Fig.3, in order for the safe to be properly secured.

4. Measure the distance between the joists, then deduct 336mm from that measurement. Divide the result by 2 to determine the thickness of the battens.
5. Ensure the battens are of sufficient size to fully support the safe, then secure them to the joists using four suitably sized wood screws.
6. Lower the safe into the space between the battens, and ensuring the top face is flush with the floorboards, secure it to the battens using the fixing screws supplied.

**NOTE:** Expansion bolts are also supplied, as it may be desired to flush fit the safe into a wall cavity.

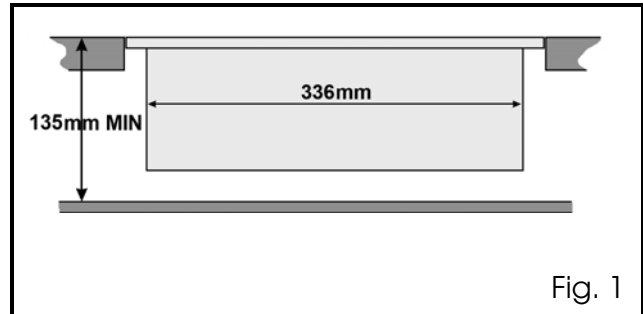

Fig. 1

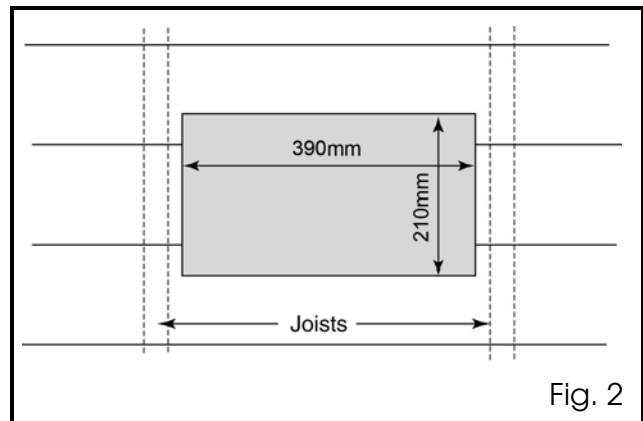

Fig. 2

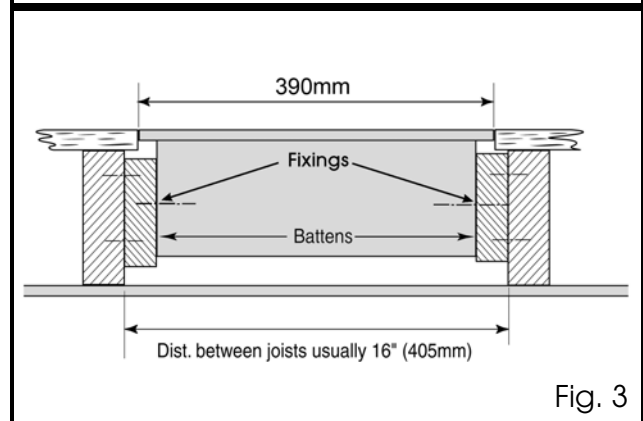

Fig. 3

# **IMPORTANT**

## **Safe Registration**

Please visit

[www.clarkeinternational.com/safe-registration/](http://www.clarkeinternational.com/safe-registration/)  
or scan the QR code below  
and register your new Clarke Safe



Please identify the key number before your safe is installed. If you fail to register and subsequently lose your key, we will be unable to provide you with a replacement. It is therefore in your own best interest to register immediately.

Record the key number here:

---

**NOTE: DO NOT store this manual or spare key  
in your safe**